

MODEL	FORCE [N]	POWER SUPPLY	DESCRIPTION
MVE504R-65	400	24 Vac/dc	Long yoke, modulating/float- ing control with position emer- gency return with totally open or closed valve selectable through jumper, IP65
MVE506R-65	600		
MVE510R-65	1000		
MVE515R-65	1500		
MVE504SR-65	400	24 Vac/dc	Short yoke, modulating/float- ing control with position emer- gency return with totally open or closed valve selectable through jumper, IP65
MVE506SR-65	600		
MVE510SR-65	1000		
MVE515SR-65	1500		

## APPLICATION AND USE

MVE5xxR-65 is a flexible electro-mechanical actuator equipped with an electronic fail safe function for the control of two-way and three-way globe valves in:

- Heating and cooling systems;
- Air Handling Units;
- District heating plants;
- Industrial temperature control systems.

The actuator is endowed with an electronic emergency return function which operates through the use of ultracapacitors whose life is about 10 years if the actuator operates within the operation limits declared in this data sheet.

The emergency position (retracted or extended stem) is set through the use of a jumper which can be easily reached (look at paragraph "DIP switches and jumper settings").

The actuator is supplied with totally discharged ultracapacitors and at its first start a pre-charge phase of 130s max will be necessary.

N.B.: in this condition during the first 20-30s no LED signal on the upper ultracapacitors control board will be revealed; when this interval has elapsed the RED LED will power on (ultracapacitors charging phase, look at table on page 7).

During this phase all the functions of the actuator are inhibited and the charge status of the ultracapacitors is signalled through 2 LEDs (look at paragraph "Standard LEDs behaviour").

MVE5xxR-65 can be controlled either by a proportional (modulating) signal or by an increase/decrease (floating) signal.

It is easy to mount and connect the actuator. Direct mounting is possible to any CONTROLLI flanged valve. Linkage kits are available for CONTROLLI threaded valves as well as for valves of other manufacturers. The actuator has a fine resolution (500 steps on the full stroke range) for accurate fluid control and it is able to self-calibrate on a different stroke without the need of any user action (this function is DIP switch selectable on the field).

MVE5xxR-65 has intelligent behavior and alarm functionality in case of unexpected operation, feedback of alarms to the user is provided by LEDs (GREEN and RED) on the actuator upper control board.

N.B.: do not use the actuator if not coupled with its relating valve.

MVE5xxR-65 is suitable for harsh environment requiring IP65 protection degree.

**Controlli S.p.A.**  
16010 Sant'Olcese (GE)  
Tel. 010 73 06 1  
Fax. 010 73 06 870/871  
[www.controlli.eu](http://www.controlli.eu)

The device contains electrical and electronic components and is not allowed to be disposed of as household refuse. All locally valid regulations and requirements must be observed.



## OPERATION

The actuator is endowed with an electronic emergency fail safe function which, in case of power failure, allows to close (or to open) the valve and to go back to the set position through the jumper.

The actuator commutes the control signal (modulating or 3-point floating) from the controller into a valve position. A modern brushless DC motor in the actuator drives a gear train and a worm gear – screw jack mechanism convert the motor revolutions into accurate and repeatable linear movements.

### Control Signal

MVE5xxR-65 can be controlled by one of 2 main control types.

- 3-point floating ;
- Modulating (proportional) signal with filed selectable range (e.g., 0-10Vdc, 2-10Vdc, 0-5/2-6Vdc, 5-10/6-10Vdc and 4-20mA).

### Manual Override

There is a manual operation handle on the actuator. When it is lowered (manual override ON), the power supply to the motor power stage circuitry is cut and the motor stops. The actuator can be operated manually and the valve positioned accordingly.

The manual override lever stays in position until it is raised again, then board and motor will be powered again. At the end of this operation the actuator moves to initial position (on the basis of DIP 1 setting) then it follows the control signal. When the manual override is engaged the GREEN and the RED LED on the lower electronic board are ON.

Manual operation handle can also be used to modify any DIP switch setting or as re-set function after any alarm occurrence.

The actuator is supplied with the manual override lowered (ON). It is not necessary to remove power supply to modify DIP switches setting.

### Position Feedback

The actuator provides a feedback signal of:

- 2-10Vdc in direct or reverse action (look at DIP n. 1 settings)
- 1Vdc during the emergency return phase

### Calibration

MVE5xxR-65 is endowed with an automatic stroke calibration function, but it can be calibrated also manually. The actuator is delivered with DIP n. 7 set to auto. Manual calibration is not necessary unless maintenance is required on the valve or certain alarm functions are desired.

### End Point Auxiliary Switches (with accessory DMVE)

End point switches change over when the valve is fully open or closed. They are free contacts with 24Vac/dc, 4A max voltage on terminals. End point switches can be utilized to indicate valve stroke end positions and for relay control of additional plant equipment. When the actuators are controlled individually or in sequence, it is possible to use the end switches to toggle when the valve is fully open or fully closed. The auxiliary switch position according to control signal (Y) is shown in the picture below.

Control signal (Y)	Relay KC1	Relay KC2
0-0,5Vdc	KC1 to K2	KC2 to K3
0,5-9,5Vdc	KC1 to K1	KC2 to K3
9,5-10Vdc	KC1 to K1	KC2 to K4

### Diagnostic

The actuator is provided with a self diagnostic algorithm able to detect faulty conditions:

- stroke calibration out of range 5-60mm;
- unexpected stall condition (e.g. valve stuck or extra stroke due to actuator link loose);
- voltage supply out of range.

These faulty conditions are signalled via the GREEN and RED LED on the lower electronic board blinking accordingly (see "Diagnostic – Alarm Function Table").

### IP65

Protection against water and solid object IP65 is guaranteed by internal seals, IP65 cable gland and the proper engineering of the enclosure.

One IP65 PG13,5 cable gland and one IP65 PG13,5 plug are supplied with the actuator.

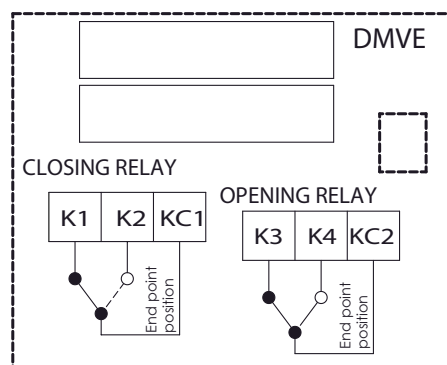

## TECHNICAL FEATURES

DESCRIZIONE		MVE504R-65 MVE504SR-65	MVE506R-65 MVE506SR-65	MVE510R-65 MVE510SR-65	MVE515R-65 MVE515SR-65
Supply voltage L1 Ln		AC: 24Vac ±20% 50-60Hz; DC: 22-30Vdc (Reference Ln)			
Power consumption (running)		10VA/4,5W	13VA/6W	18VA/8W	21VA/11W
Power consumption (Holding)		8VA/4W	11VA/5W	11VA/5W	13VA/7W
Charging phase consumption		32VA/18W			
Ultracapacitors charging phase (if totally discharged)		130 s			
Running and emergency return time		1,1 s/mm			
Running time	Modulating	18 s (for Controlli valves with stroke 16,5 mm)			
		28 s (for Controlli valves with stroke 25 mm)			
		50 s (for Controlli valves with stroke 45 mm)			
	Floating	60 s			
Transformer Size [VA]		20	50	60	80
Stroke		5-60 mm (limited to 30 mm for MVE5xxSR-65)			
Force		400 N	600 N	1000 N	1500 N
Duty cycle		max 50%/60 minutes			
Analogue input Y M		voltage 0-10V - impedance > 100kΩ (range: 0-10Vdc, 2-10Vdc, 0-5/2-6Vdc, 5-10/6-10Vdc); 500Ω (range 4-20mA)			
Digital inputs Y1 Y2		connection to L1 or Ln when powered in AC; connection to Ln only when powered in DC			
Output V+		voltage 16Vdc ± 0,5V; max load 25mA,			
Output U		voltage 2-10Vdc (0-100%); max load 2mA; voltage 1Vdc (during the emergency return phase)			
Number of cycles of emergency		1.000			
Type of movement		linear			
Ambient temperature		operation -10T55°C; storage -20T55°C			
Ambient Humidity		max 90% RH			
Protection degree		IP65			
Insulation class		III			
Standard		Emission/Immunity EMC 2014/30/UE according to EN 61326-1:2013 standard			
Material		housing: aluminium - cover: ABS plastic			
Colour		aluminium / white			
Weight [kg]		1,7 (MVE5xxR-65); 1,6 (MVE5xxSR-65)			

## ASSEMBLING

The actuator can be mounted with any orientation but never up-side down. When the fluid temperature exceed 120°C the actuator shall be mounted leaning 45°.

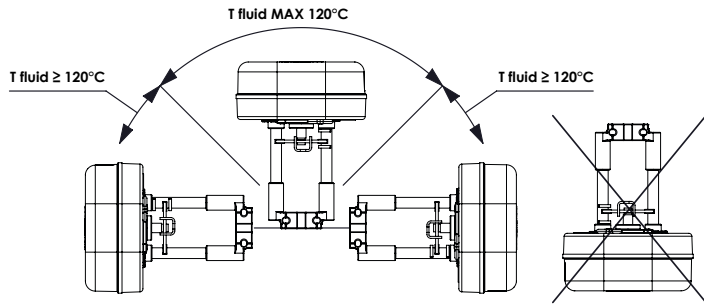

To mount the actuator on to a valve, position the valve stem to the bottom of its travel, slide the actuator onto the valve neck, adjusting with the manual override the screw jack position so the square nut on the valve spindle fits into the groove on the cross bar. Then slide the brace into the groove on the valve neck and secure the nuts.

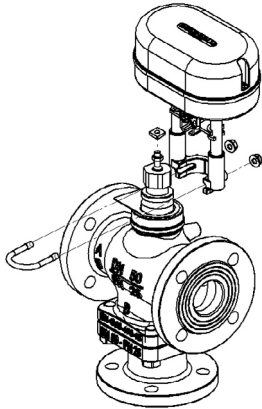

See mounting instructions for full details (MVE5xxR\_DIM265).

## MAINTENANCE

The actuator is maintenance free.

## ACCESSORIES

<b>DMVE</b>	Endpoint auxiliary switches (electrical rate 24V AC/DC, 4A)
<b>GMVE</b>	Thermal insulation for MVE actuators *
<b>GMVES</b>	Thermal insulation for MVE.S actuators *
<b>KIT-P13.5</b>	10 cable glands kit (nuts and gaskets included)
<b>KIT-T13.5</b>	Kit 10 caps for cable glands hole (nuts and gaskets included)
<b>248</b>	Stem heater (suggested when the fluid temperature is below 0°C) *

\* It is not possible to install both thermal insulation (Gxxxx) and stem heaters.

## COMPATIBLE VALVES AND ACTUATORS

CONTROLLI VALVES	MVE5xxR-65	MVE5xxSR-65
Current Controlli valves (except for 2-3TGB.F PN16)	•	-
VSXT09PBP, VSXT10PBP	-	only with MVE504SR-65
2-3TGB.F PN16	-	•
Controlli valves with threaded M40 connections (except for VSB-VMB, VSB.F-VMB.F PN16)	with AG51	-
VSB-VMB, VSB.F-VMB.F PN16	with AG52	with AG63
OTHER MANUFACTURERS VALVES	MVE5xxR-65	MVE5xxSR-65
Belimo H2..X-S e H3..X-S	with AG82	with AG82
Siemens *	with AG70-10 with AG70-14	-
Danfoss (VR/VF (S) models)	with AG60-07	-
TAC DN15-V298	with AG60-08	-
TAC DN15-V2XX/V3XX	with AG60-09	-
Honeywell **	with AG60-10	-
Airtek	with AG60-11 with AG60-12	-
Johnson Controls VB7816-2111	with AG66	-
Johnson Controls BM-3018-3300	with AG67	-
MUT MK DN50-150	with AG69	-
Tac Venta	•	-

\* AG70-10 for valves having stem Ø 10mm  
AG70-14 for valves having stem Ø 14mm

\*\* valid for the following models  
M6: V176A,B, V538C  
1/4": V5011A

## ELECTRIC CONNECTIONS

Remove the cover screw with a screwdriver and then remove the cover as shown in the picture below.

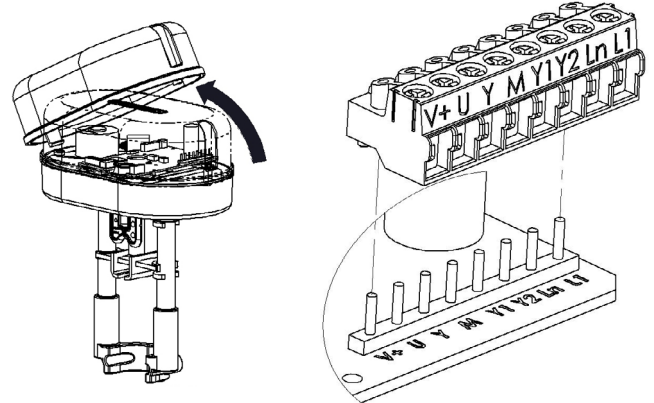

The actuator is equipped with a 8 poles removable terminal block; each pole of the plug is clearly marked and the same label are reported on the electronic board. Before powering up the actuator make sure the plug is properly connected to the board and the label on the plugs and on the board match.

Use cable gland IP65 PG13,5 model.

Label	Description	Function	Cable type	Max wire length
L1	24Vac/dc	Power supply	AWG 16 (min 1mm <sup>2</sup> - max 1,5mm <sup>2</sup> )	75m
Ln	0V			
Y	0-10Vdc	Modulating control input	AWG 20 (min 0,5mm <sup>2</sup> - max 1,5mm <sup>2</sup> )	200m
M	0V (common)			
Y1	Open	Floating control input	AWG 20 (min 0,5mm <sup>2</sup> - max 1,5mm <sup>2</sup> )	200m
Y2	Close			
V+	16Vdc	Voltage output max 25mA	AWG 20 (min 0,5mm <sup>2</sup> - max 1,5mm <sup>2</sup> )	200m
M	0V (common)			
U	2-10Vdc*	Feedback output signal	AWG 20 (min 0,5mm <sup>2</sup> - max 1,5mm <sup>2</sup> )	200m
M	0V (common)			

\* 1Vdc during the emergency return phase

### 3-point floating control (sink connection)

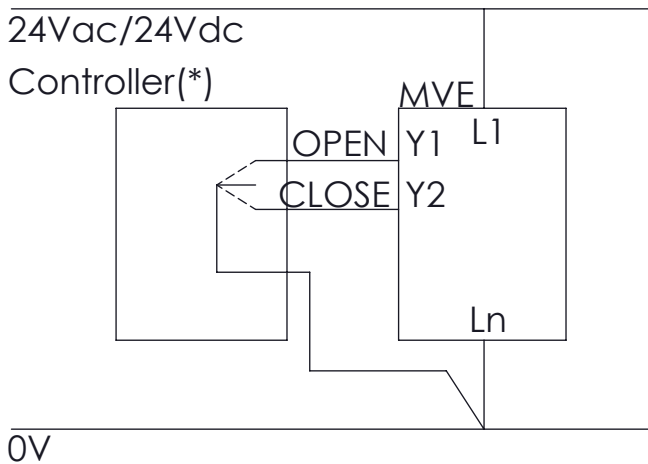

### 3-point floating control (source connection)

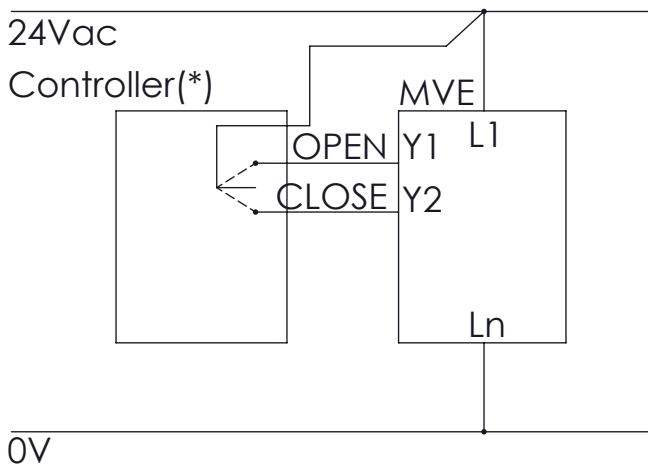

### Modulating control (0-10Vdc)

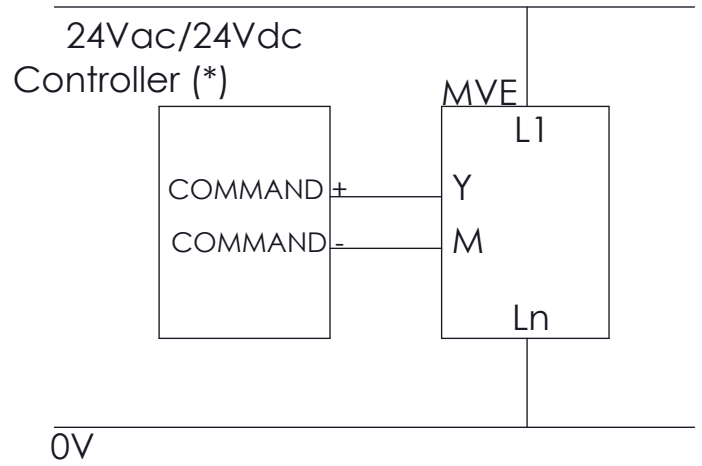

**N.B.:** M and Ln signal are internally connected

(\*) MVE contain a single half-wave rectifier power supply. They must not be powered with transformers that are used to power other devices using not isolated double half-wave rectifier power supply.

### TERMINAL BLOCK

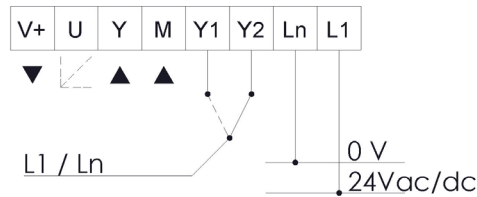

**Matching between MVE5xxR-65 terminal block and others CONTROLLI actuators with emergency device**

G	G0	MX	G1	X1	VH	VC	Y	MVH56FA (MVER with opened jumper)
G	G0	MX	G1	X1	VH	VC	Y	MVH56FC (MVER with closed jumper)
L1	LN	M	V+	Y	Y1	Y2	U	MVER

## DIP SWITCHES AND JUMPER SETTINGS

Set the DIP switches according to the tables here below. In order to be sure that any modification has been accepted by the actuator, power down and power up it again or act on the manual operation handle to be sure that settings will be recognized.

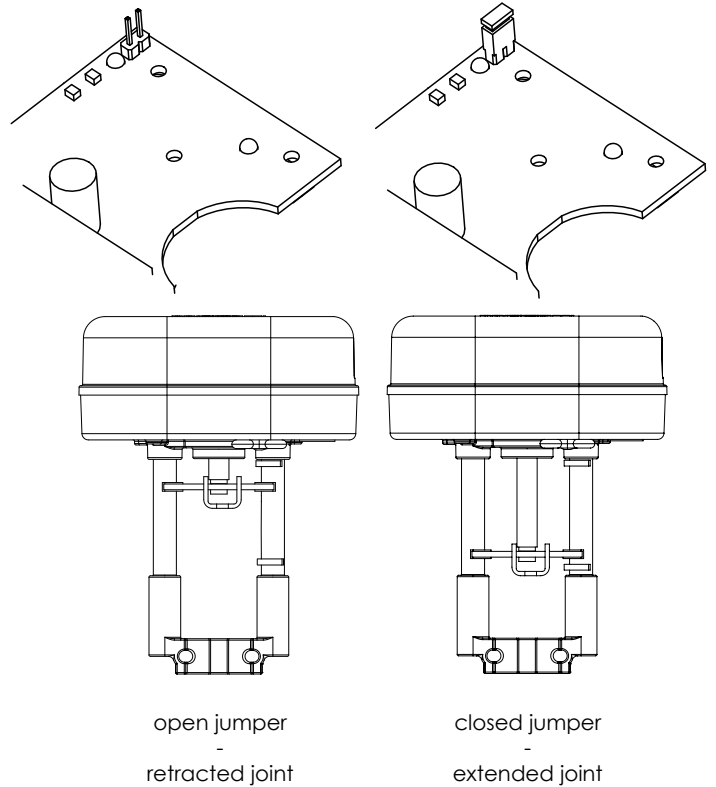
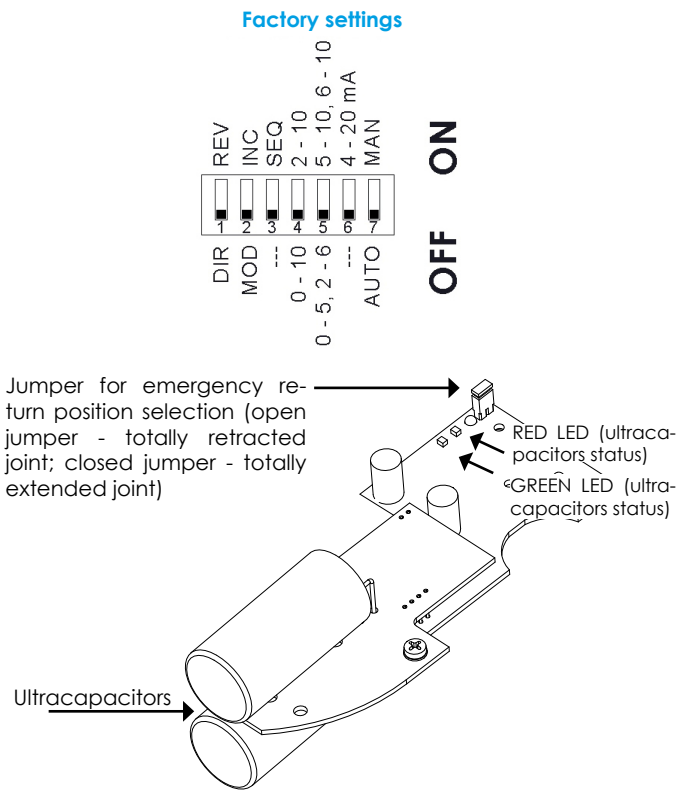

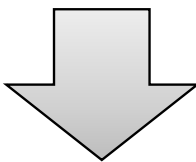
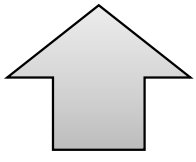
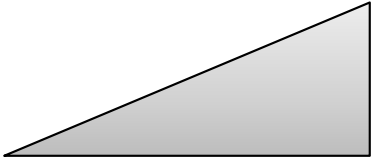
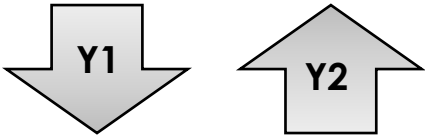
DIP switch	OFF	ON
1	U= feedback Direct Action  U = 2V U = 10V	U= feedback Reverse Action  U=10V U = 2V
2	Modulating Control (MOD) (Input between Y [+] and M [-]) 	3 point floating (INC) ( Y1 open-extend , Y2 close-retract connected L1 or Ln if powered in Vac; if powered in Vdc connected necessarily to Ln ) 
3	-	Selection of sequence mode, control range defined by DIP n. 5
4	Modulating Control 0-10Vdc (DIP n. 2 OFF only)	Modulating Control 2-10Vdc (DIP n. 2 OFF only)
5	Sequence Control 0-5Vdc with DIP n. 4 OFF only Sequence Control 2-6Vdc with DIP n. 4 ON only (DIP n. 3 ON only)	Sequence Control 5-10Vdc with DIP n. 4 OFF only Sequence Control 6-10Vdc with DIP n. 4 ON only (DIP n. 3 ON only)
6	Voltage Input Signal (input between Y [+] and M [-])	Current Input Signal 4-20mA (input between Y [+] and M [-]). In this case DIP n. 4 must be set to ON.
7	Automatic Calibration: the actuator updates the stroke range every time an unexpected mechanical stop is detected for at least 10s	Manual Calibration: the actuator calibration is started moving the DIP from OFF to ON or vice versa. With DIP in ON in case of extra stroke or if an unexpected endpoint is detected, the actuator will never update the stroke

N°	LEDs behaviour	Error	Actuator use	Actuator behaviour		Typical trouble shooting condition	Reset procedure
				Automatic calibration (DIP N. 7 OFF)	Manual calibration (DIP N. 7 ON)		
1	RED ON	Valve stroke less than 5mm	Calibration/ first installation	The actuator pushes/pulls 2 times (unexpected stall) trying to remove the possible obstacle. After 2 tries an alarm is signalled and the actuator moves to initial position and does not respond to control signal. Stroke value is not updated because out of range	The actuator pushes/pulls 2 times against endpoint during calibration and the actuator moves to the initial position and then it does not respond to the control signal. The actuator keeps the previous stroke	Valve with a stroke length lower than 5mm	Remove power and power up again
2	RED LED quick blinking + GREEN ON	Stroke longer than 60mm	Calibration/ first installation	The actuator exits the 60mm stroke range and it moves toward the new stroke limit signalling an anomaly. The actuator pushes/pulls 2 times against the new stroke limit, then it goes back to the initial position still signalling the anomaly until it is not within 60mm. The actuator does not calibrate the stroke after 10s (wrong range)	The actuator exits the 60mm stroke range and it moves toward the new stroke limit signalling an anomaly. The actuator pushes/pulls 2 times against the new stroke limit, then it goes back to the initial position still signalling the anomaly until it is not within 60mm. The actuator does not calibrate the stroke after 10s (wrong range)	Valve with a stroke length longer than 60mm	Remove power and power up again
3	RED Quick Blinking	Unexpected stall within the calibrated stroke range	normal operation	The actuator tries 5 times against the new stall condition and then after 10s the actuator updates the new stroke length	The actuator tries 5 times against the new stall condition. At the end of the attempts the fault will be signalled. The actuator does not update the new stroke length, but after 60s makes other attempts to verify the stall condition	Valve stuck	Inverted control signal
4	RED Quick Blinking	Stroke longer than expected	Normal operation	The actuator moves toward the new stall condition with a lower speed; after 10s the actuator updates the new stroke value	The actuator moves toward the new stall condition with a lower speed; after 10s the actuator does not update the new stroke value	Stem connection loose or valve damaged	Inverted control signal
5	RED slow Blinking	Low Power Voltage	Normal operation	The actuator is still working but performance cannot be guaranteed	The actuator is still working but performance cannot be guaranteed	1. Wrong transformer size 2. Unstable power	Correct Voltage Power
6	RED slow Blinking	High Power Voltage	Normal operation	The actuator is still working but performance cannot be guaranteed	The actuator is still working but performance cannot be guaranteed	1. Wrong transformer size 2. Unstable power	Correct Voltage Power

## STANDARD LEDs BEHAVIOUR

### Lower electronic control board

N°	LEDs behaviour	Actuator status
1	GREEN ON	The actuator arrived at the extreme point of the stroke
2	GREEN BLINKING	The actuator is moving or arrived at the intermediate point of the stroke
3	RED GREEN BLINKING ALTERNATING	Calibration or initialization phase
4	RED GREEN ON	Manual control enabled, the actuators ignores the control signal. ATTENTION! The electronic board is electrically supplied
5	RED GREEN BLINKING SIMULTANEOUS	The actuator is in emergency return phase

### Upper electronic board

LED	ULTRACAPACITORS STATUS
GREEN	ultracapacitors charged
RED	ultracapacitors discharging
OFF	ultracapacitors totally discharged

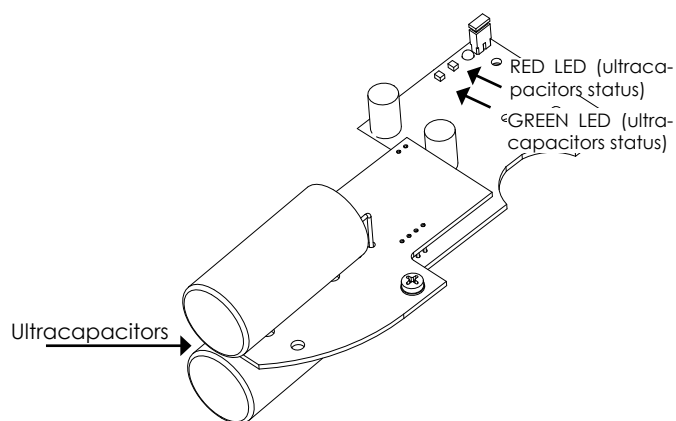

### DIMENSIONS [mm]

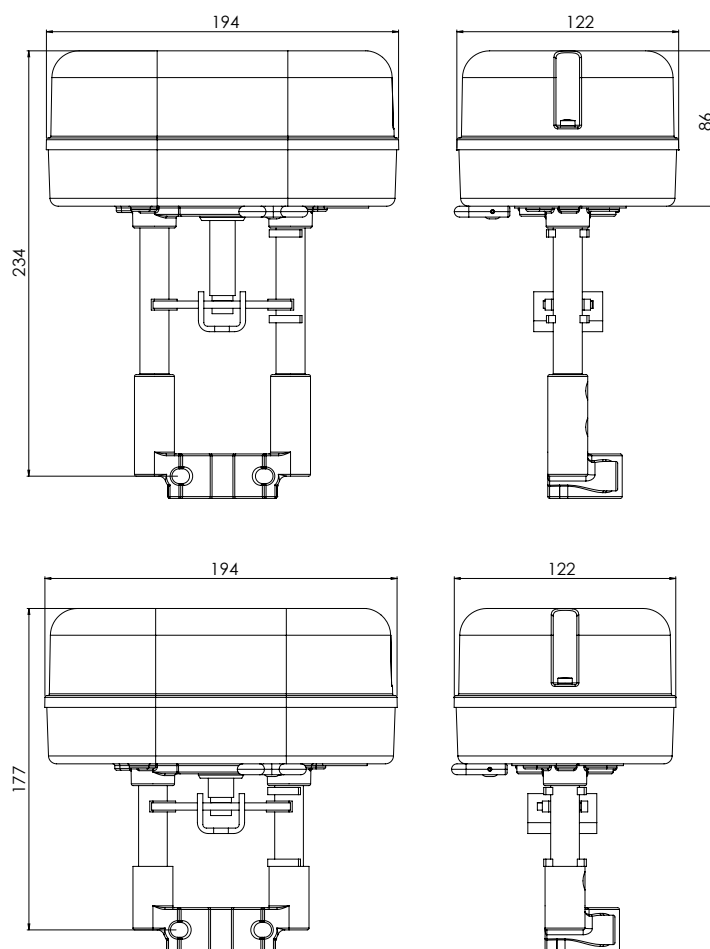

The performances stated in this sheet can be modified without any prior notice